

# APRC90AT manual



## Table of contents

- 1. Safety
  - 1.1. Intended use
  - 1.2. Labels in this manual
  - 1.3. General safety instructions
- 2. Preparations for use
  - 2.1. Unpacking
  - 2.2. Package contents
- 3. Installation
  - 3.1. Connecting to the mains
  - 3.2. Install batteries
- 4. Functions
  - 4.1. APRC90AT
- 5. Operation
  - 5.1. Quick start
  - 5.2. Radio functions
  - 5.3. CD functions
  - 5.4. USB functions
  - 5.5. AUX IN
  - 5.6. Auto Power System (APS)
- 6. Cleaning and maintenance
  - 6.1. Handle and care of a disc
- 7. Technical data
- 8. Disposal of used electrical and electronic equipment

# 1.Safety

## 1.1. Intended use

The device functions as a portable radio/CD audio player. The device can play music (MP3) via CD and USB. It is also possible to play music via the AUX port.  
Read the manual carefully before the first use.

## 1.2. Labels in this manual



**WARNING** A warning means that injury or death is possible if the instructions are not obeyed.



**CAUTION** A caution means that damage to the equipment is possible.



A note gives additional information, e.g. for a procedure.

## 1.3. General safety instructions



**WARNING** Do not put force on the appliance. The appliance can fall and can cause serious injury.



**CAUTION** Do not spill any liquid on the appliance.



**WARNING** Do not insert any objects in the ventilation holes.



**CAUTION** Do not block the ventilation holes.



This appliance is double insulated; therefore no earth wire is required. Always check that the mains voltage corresponds to the voltage on the rating plate.

## 2.Preparations for use

### 2.1. Unpacking

- Unpack the appliance carefully.

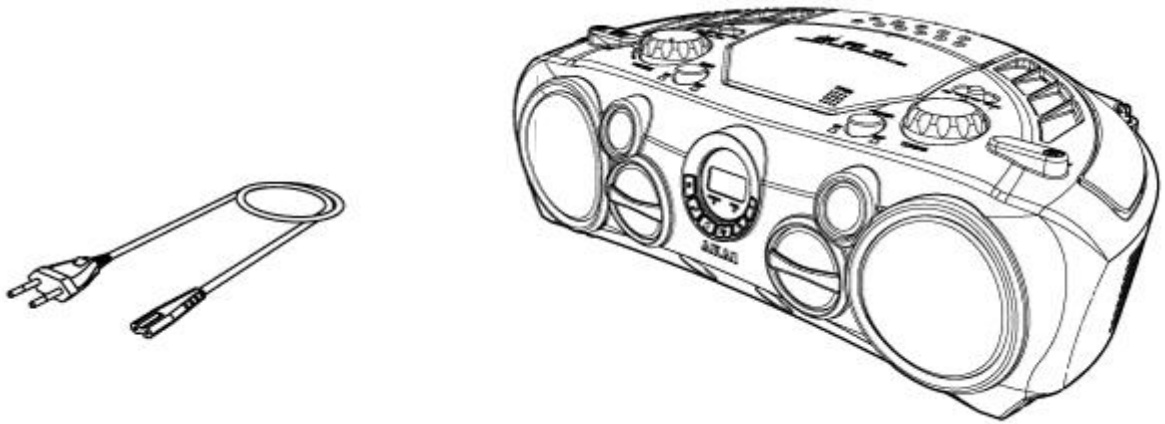

- Check the package contents as described below. If any item is missing, please contact your reseller.
- Remove the labels from the front panel carefully if present.



We recommend that you retain the original carton and packing materials in case it ever becomes necessary to return your product for service. This is the only way to safely protect the product against damage in transit. If you do dispose of the carton and the packing materials, please remember to recycle with due care to the environment.

### 2.2. Package contents

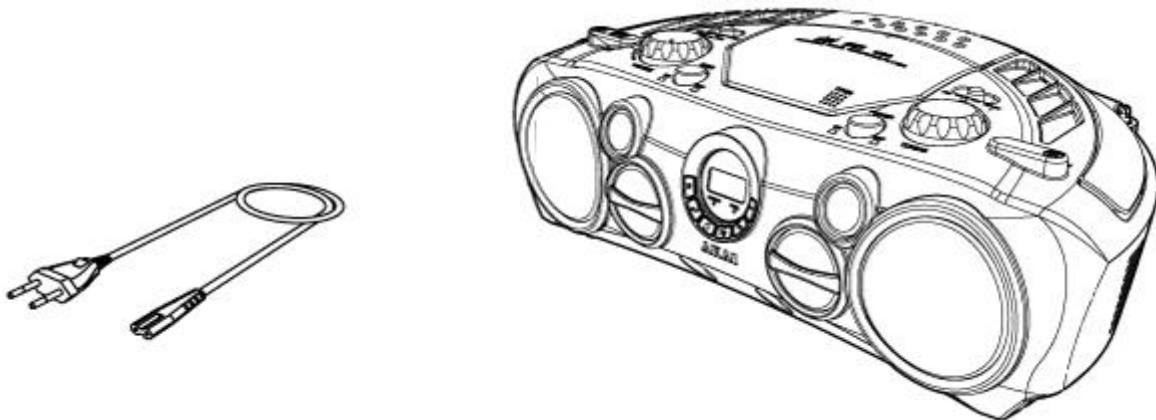

The following items are included in the received package:

- 1 x Quick start guide
- 1 x Mains cable



If any item is missing, please contact your reseller.

## 3. Installation

- Put the appliance on a horizontal flat surface.
- Connect the appliance to the mains.



CAUTION Do not put the appliance near a heat source.



CAUTION Do not expose the appliance to direct sunlight.



This appliance is equipped with rubber feet to prevent it from moving. The feet are made from non-migrating material specially formulated to avoid leaving any marks or stains on furniture. However, certain types of furniture polishes, wood preservatives or cleaning sprays cause the rubber to soften and leave marks or a residue on the furniture, and potentially risk the surface to become damaged. To prevent damage to wooden surfaces, we recommend that you apply self-adhesive pads to the bottom of the rubber feet before installation.

### 3.1. Connecting to the mains

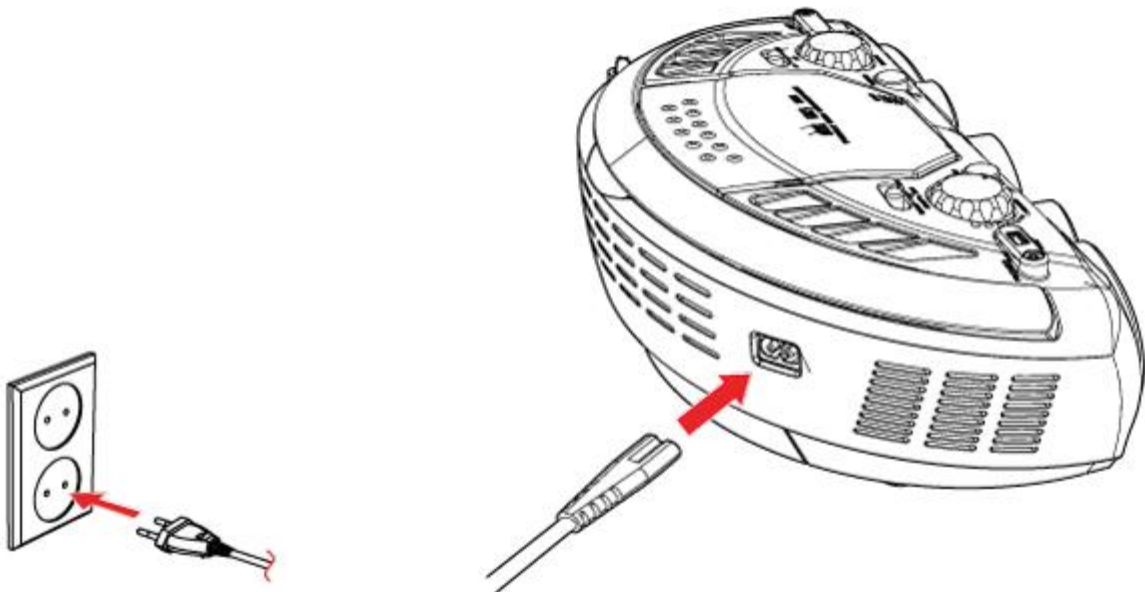

Connect the 8-shaped connector of the power cable to the device's power connection.

- Connect the mains plug to a wall socket.

### 3.2. Install batteries

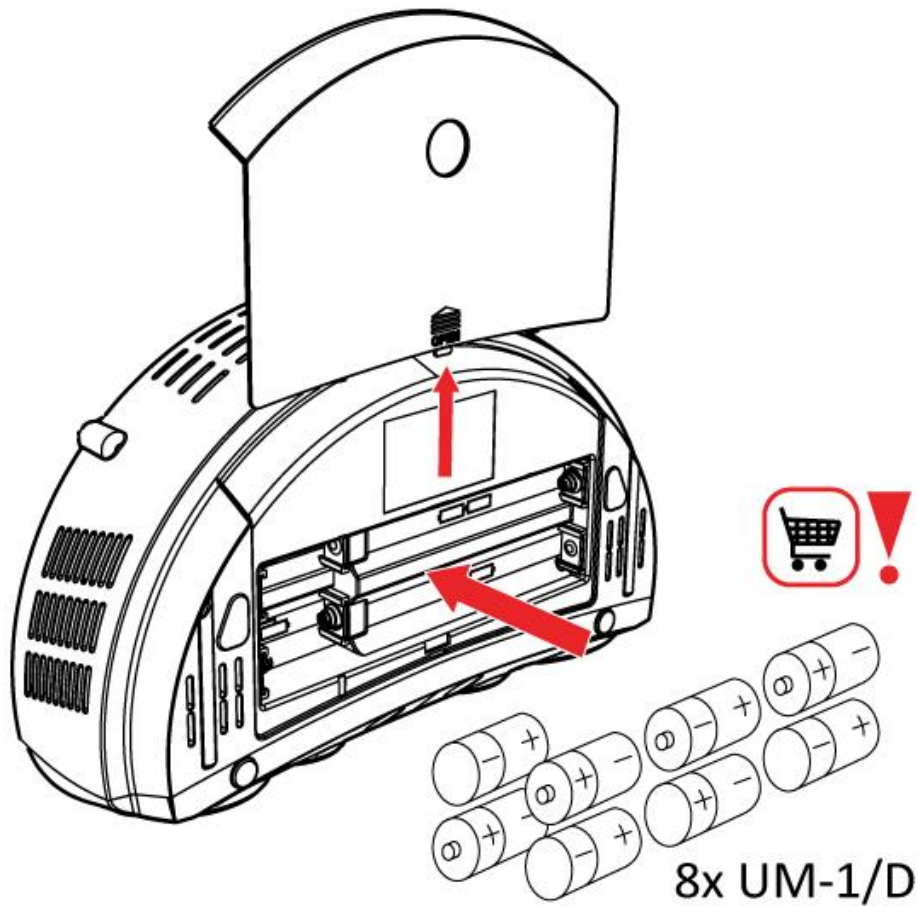

The appliance can also be operated on battery power. For this purpose, the appliance uses six batteries (UM-1 / D).



Please note: these batteries are not included.

- Batteries are not necessary for normal operation.
- If you do not use the appliance for an extended period, remove the batteries.

#### Install batteries

- Remove the battery cover.
- Insert the batteries matching the (+) and (-) polarity markings.
- Re-install the battery cover.



**CAUTION** Incorrect installation can cause battery leakage and corrosion which will damage the appliance. Corrosion, oxidation, battery leakage and any other gradually acidic defect of this nature will invalidate the guarantee.

## 4.Functions

### 4.1. APRC90AT

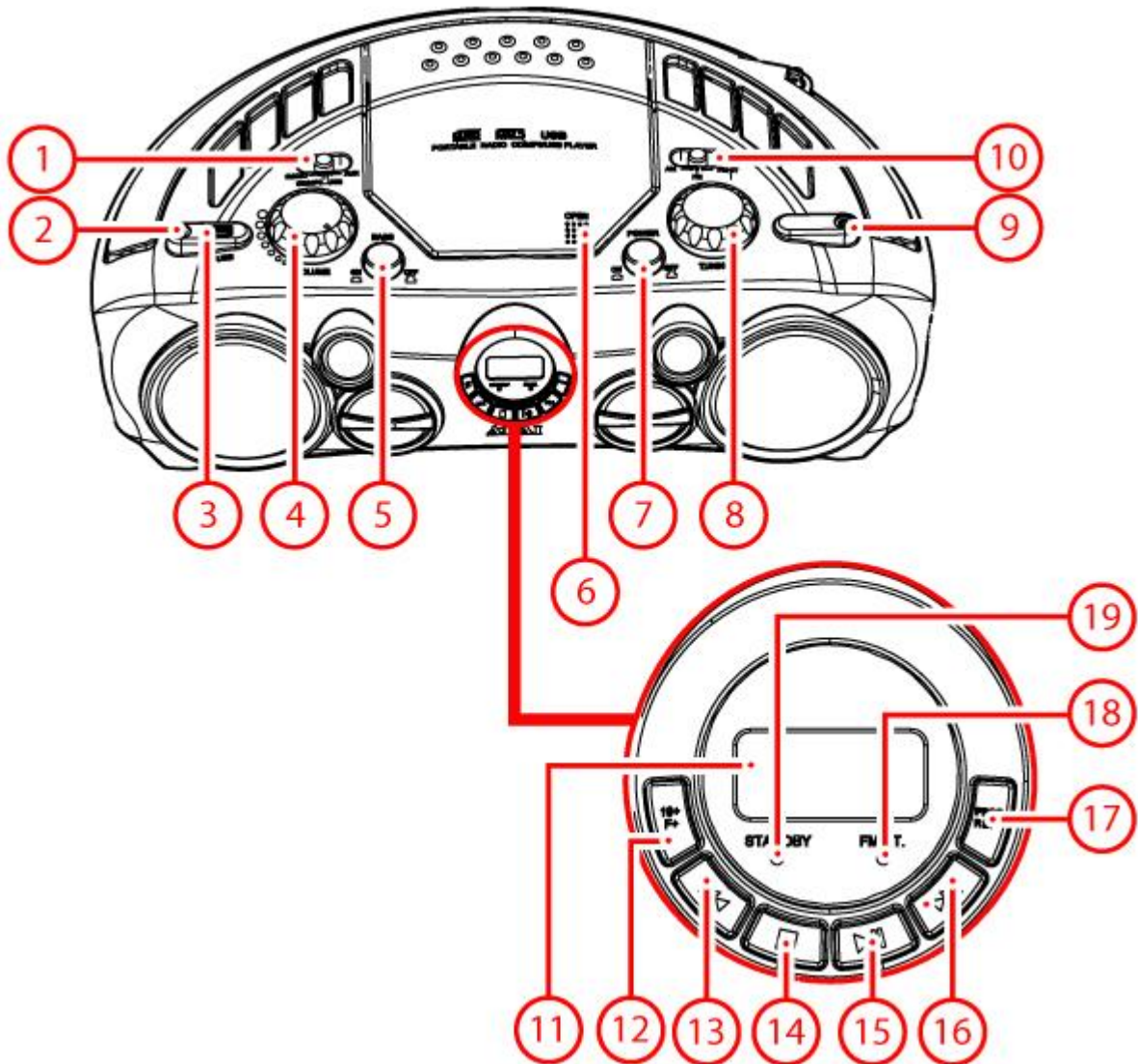

1. FUNCTION switch (RADIO-CD/MP3-USB-AUX)
2. Headphone jack
3. USB slot
4. VOLUME dial
5. BASS button
6. CD compartment
7. POWER/STANDBY button
8. TUNING dial
9. AUX IN jack
10. BAND switch (AM/FM/FM ST.)
11. Display
12. 10+/FOLDER button
13. PREV button
14. STOP button
15. PLAY/PAUSE button
16. NEXT button
17. PROGRAM/REPEAT button
18. REPEAT iFM STEREO
19. REPEAT iSTANDBY

# 5.Operation

## 5.1. Quick start

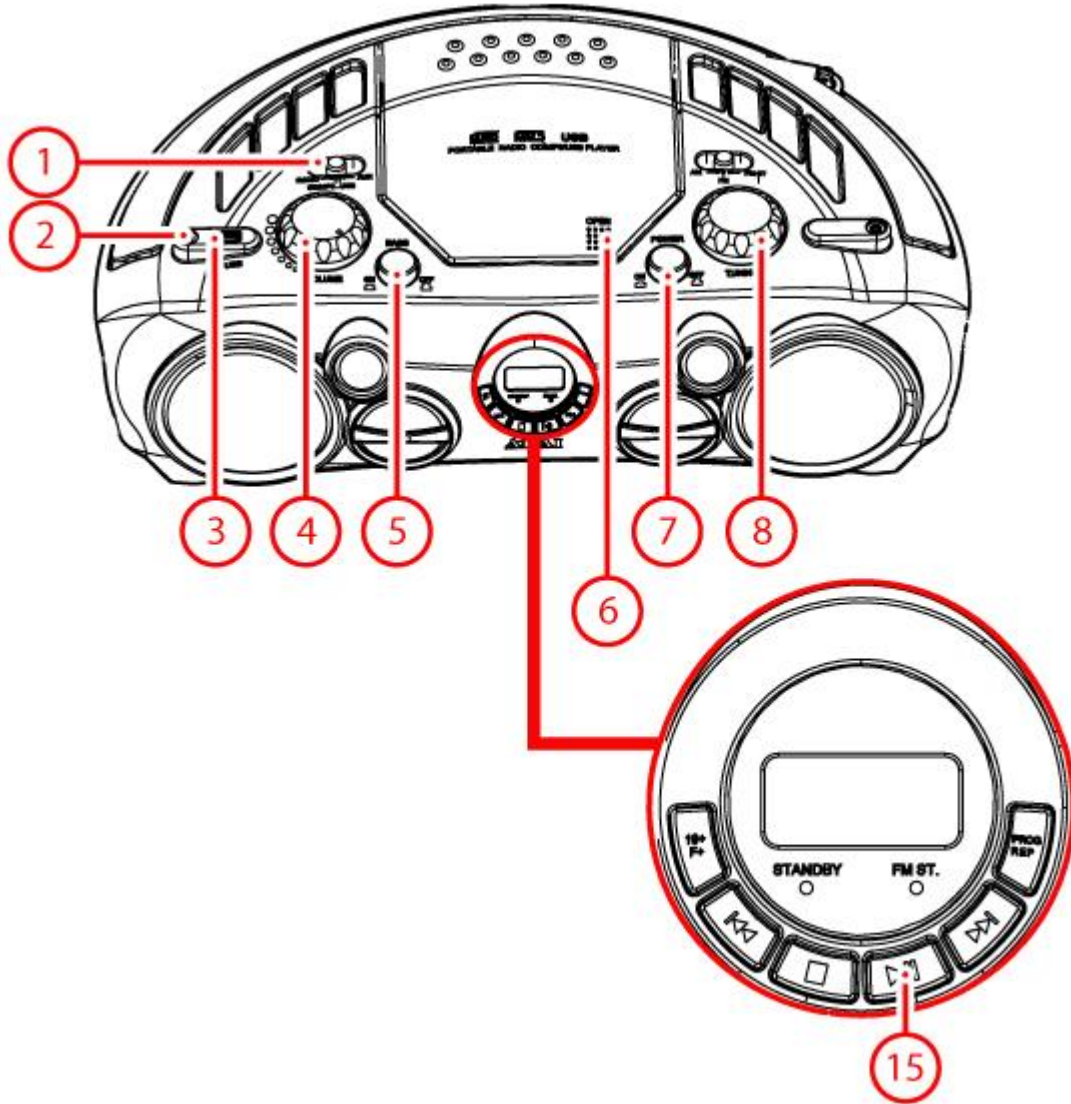

### General functions

- To switch on the appliance, press the STANDBY button . To switch back to the standby mode, press the STANDBY button again.
- To select the source mode (RADIO-CD/MP3-USB-AUX), slide the FUNCTION switch ((1)) to the desired position.
- To adjust the volume level, turn the VOLUME dial (4) until the desired level is set.
- To enable the enhanced bass, press the BASS button (5). Press the button again to disable the enhanced bass.

### Radio functions

- To select the radio function, slide the FUNCTION switch (1) to the radio position.
- Slide out the antenna

- To adjust the frequency, turn the TUNING knob (8) until the desired frequency is reached.
- For extended instructions, read the paragraph "Radio functions" further on in this manual.

### **CD functions**

- To select the CD function, slide the FUNCTION switch (1) to the CD position.

To insert a CD:

- Press the CD compartment (6) to open the appliance
- Insert the CD with the label upwards
- Close the CD compartment
- To start playback, press the PLAY/PAUSE button (15) once.

For extended instructions, read the paragraph "CD functions" further on in this manual.

### **USB functions**

- To select the USB function, slide the FUNCTION switch (1) to USB.
- Insert the USB device in the slot (3). The device can only be connected one way.
- To start playback, press the PLAY/PAUSE button (15) once.

For extended instructions, read the paragraph "USB functions" further on in this manual.

### **AUX IN jack**

- To use the AUX-IN port, slide the FUNCTION switch (1) to the position
- To connect an external audio device, insert the cable plug in the AUX IN jack (2).

For extended instructions, read the paragraph "AUX IN" further on in this manual.



## 5.2. Radio functions

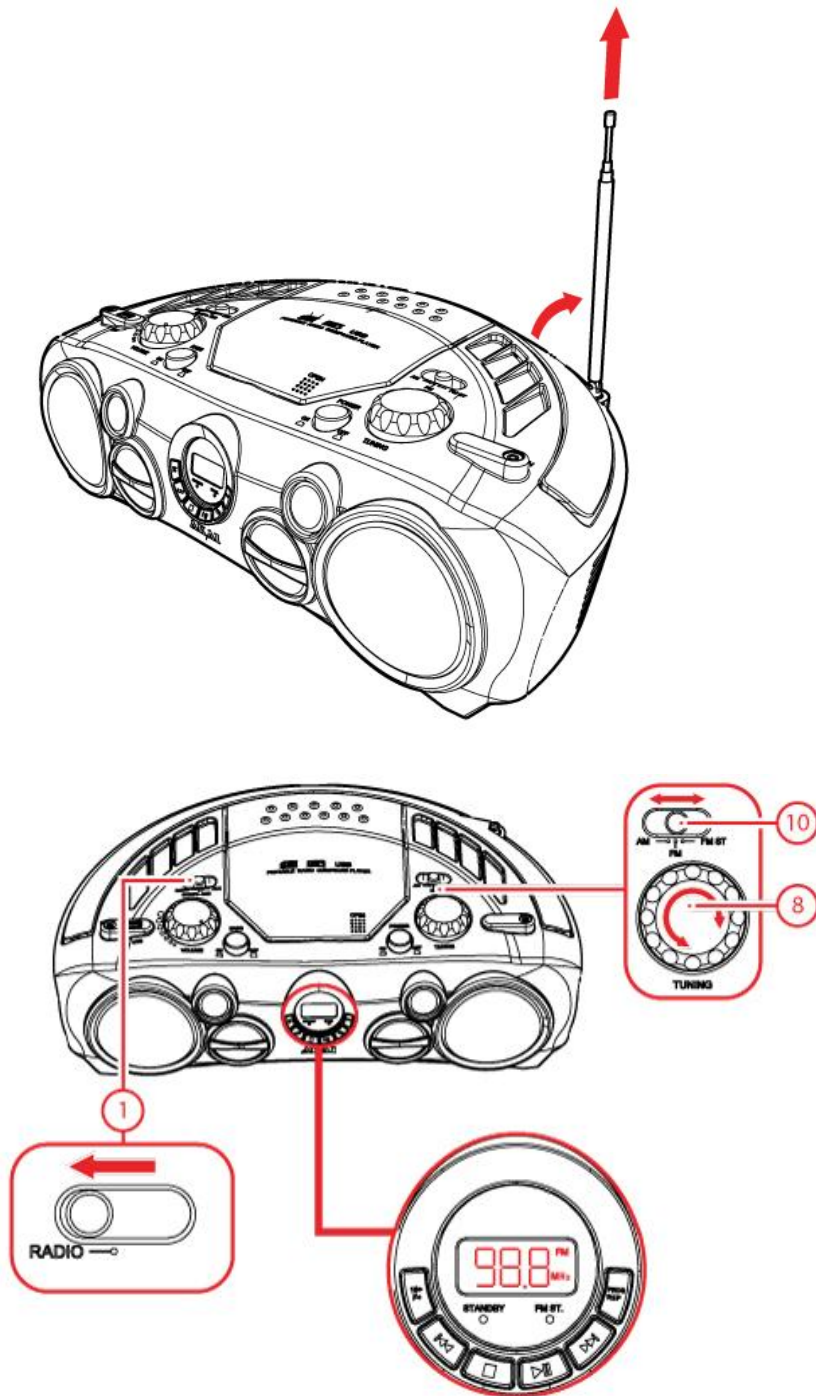

- Slide out the antenna
- To select the radio function, slide the FUNCTION switch (1) to the radio position.
- Use the switch BAND (10) to switch between AM, FM and FM Stereo.
- To adjust the frequency, turn the TUNING knob (8) until the desired frequency is reached. The frequency is shown on the display

### 5.3. CD functions

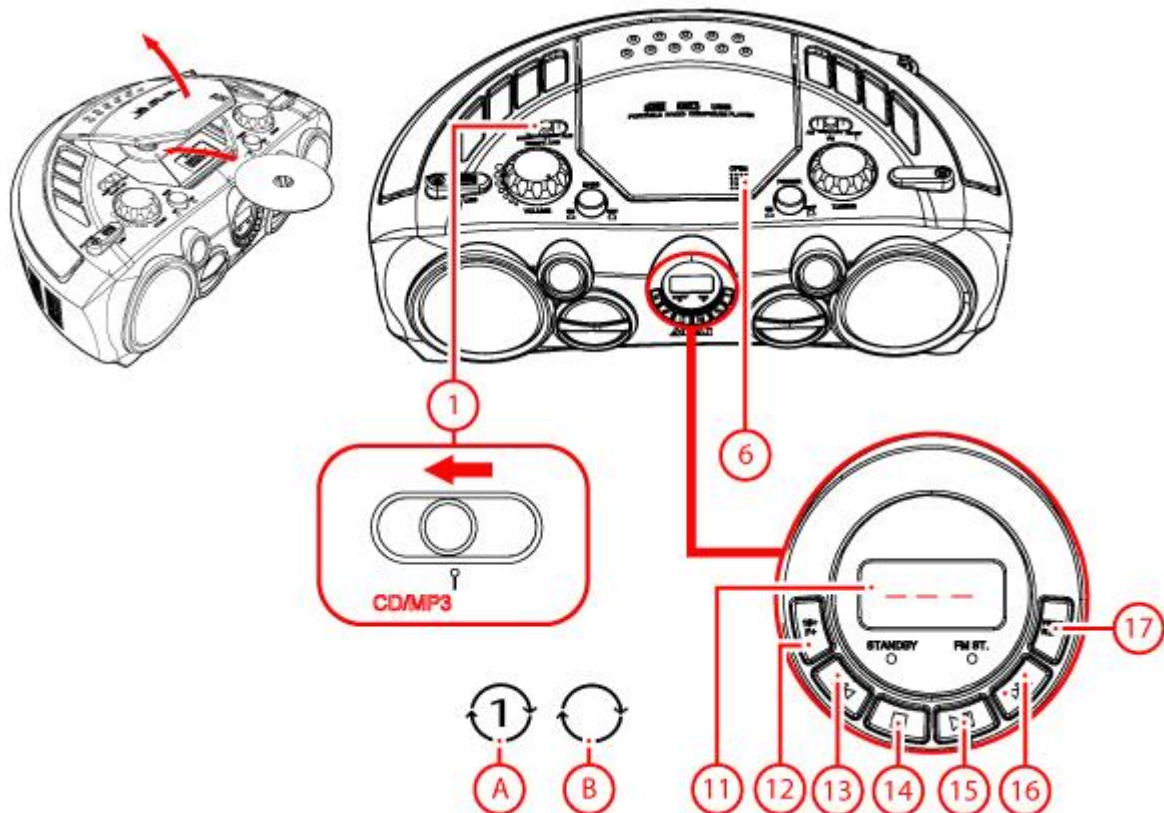

To insert a CD:

- Press the CD compartment (6) to open the appliance
- Insert the CD with the label upwards
- Close the CD compartment (6)

Playing a CD:

- To select the CD function, slide the FUNCTION switch (1) to the CD position.
- To start playback, press the PLAY/ PAUSE button (15) once.

During playback, the following functions are available:

- To select a track, press the PREV button (13) or the NEXT button (16) until the desired track is set.
- To search for a specific point on the disc, hold the PREV button (13) or the NEXT button (16) until the point is reached and release the button.
- To pause playback, press the PLAY/PAUSE button (15) once; to resume playback, press the button again.
- To stop playback, press the STOP button (14).
- Hold down the button 10+/F+ (12) to go to the following 10 numbers.
- Press the button 10+/F+ (12) to select the next folder on an MP3 disc or a USB flash drive

### **Using the REPEAT function**

- To repeat the current number, press the button PROG/REP (17) until the icon (A) appears on the display.
- To repeat all numbers, press the button PROG/REP (17) until the icon (B) appears on the display.
- (Only for MP3) To repeat all the numbers in one folder, press the button PROG/REP (17) until the icon (B) and the icon FOLDER appear on the display.
- To shut off the function REPEAT press the button PROG/REP (17) until no REPEAT icon is visible anymore.

### **Using the PROGRAM function**

To use the PROGRAM function for CD, the playback must be in STOP mode.

- To play a list of tracks (max. 20) in a program, press the PROG/REP button (17). P01 appears on the display.
- Press the PREV button (13) or the NEXT button (16) to select a desired track.
- Press the PROG/REP button (17) to confirm the selection. Repeat the previous step to select more tracks and confirm every selection with the PROG/REP button (17).
- Press the PLAY/PAUSE button (15) to start the program.
- To play the program again, press the PROG/REP button (17) after the program has finished. Press the PLAY/PAUSE button (15) to start the program again.
- To stop the program during playback, press the STOP button (14).
- To delete the program during the playback, press the STOP button (14) twice.

## 5.4. USB functions

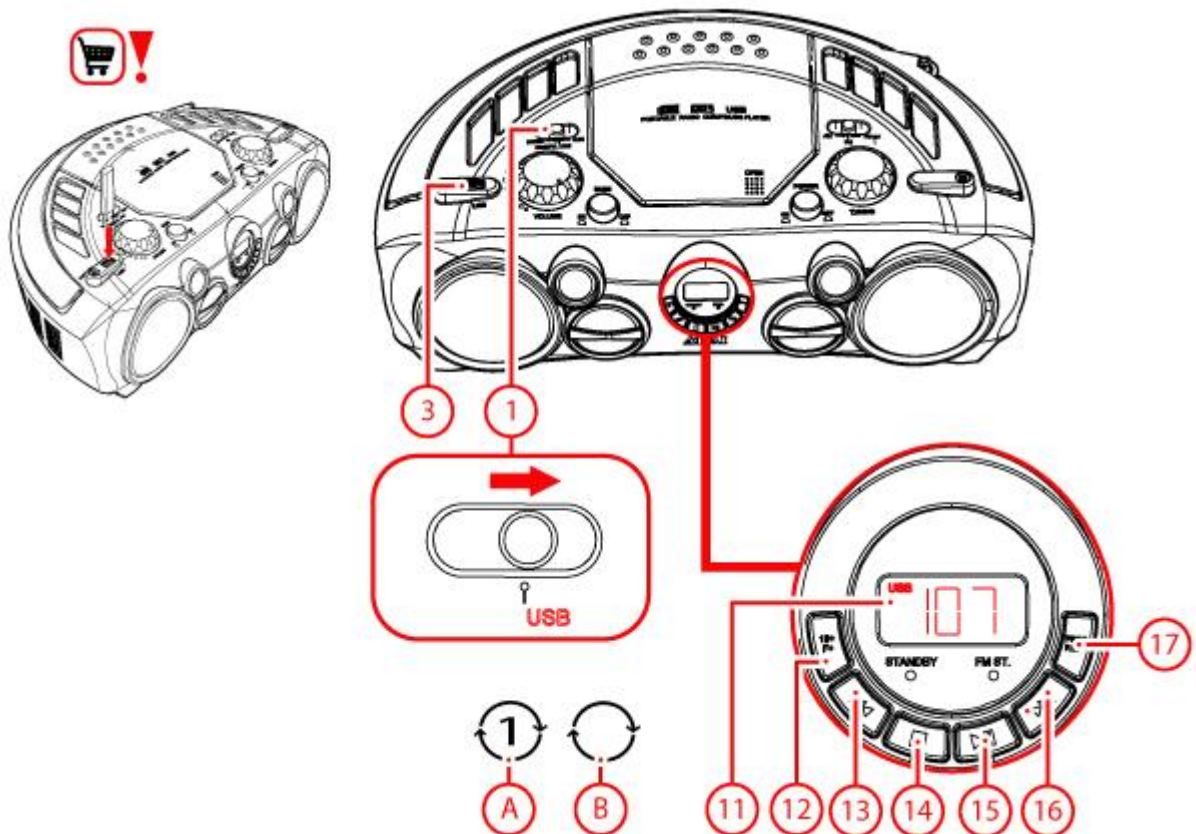

Due to the great variety of products with USB ports and their sometimes quite manufacturer-specific functions we can neither guarantee that all devices will be recognised, nor that all operating options that are possible in theory will actually work.

- Insert the USB device in the slot USB (3). The device can only be connected one way. The USB input is located at the top of the appliance.

- To select the USB function, slide the FUNCTION switch (1) to USB. After connecting the appliance, the contents are loaded. Next, the total number of tracks appears on the display (11).

- To start playback, press the PLAY/PAUSE button (15) once.

During playback, the following functions are available:

- Press and hold the PREV button (13) or the NEXT button (16) to rewind or forward the track.
- Press the PREV button (13) or the NEXT button (16) to select a desired track.
- To pause playback, press the PLAY/PAUSE button (15) once; to resume playback, press the button again.
- To stop playback, press the STOP button (14).
- Hold down the button 10+/F+ (12) to go to the following 10 numbers.
- Press the button 10+/F+ (12) to select the next folder on an MP3 disc or a USB flash drive

### Using the REPEAT function

- To repeat the current number, press the button PROG/REP (17) until the icon (A) appears on the display.
- To repeat all numbers, press the button PROF/REP (17) until the icon (B) appears on the display.
- (Only for MP3) To repeat all the numbers in one folder, press the button PROF/REP (17) until the icon (B) and the icon FOLDER appear on the display.
- To shut off the function REPEAT press the button PROG/REP (17) until no REPEAT icon is visible anymore.

### Using the PROGRAM function

To use the PROGRAM USB/MP3 function for USB, the playback must be in STOP mode.

- To play a list of tracks (max. 20) in a program, press the PROG/REP button (17). P01 appears on the display.
- Press the button 10+/F+ (12) to select the desired folder.
- Press PROG/REP (17) to confirm.
- Press the PREV (13) button or the NEXT (16) button to select the desired file.
- Press PROG/REP (17) to confirm.
- Press the PROG/REP button (17) to confirm the selection. Repeat the previous step to select more tracks and confirm every selection with the PROG/REP button (17).
- Press the PLAY/PAUSE button (15) to start the program.
- To stop playback, press the STOP button (14).
- To delete the program during the playback, press the STOP button (14) twice.
- To remove the device, gently pull it out of the slot.

## 5.5. AUX IN

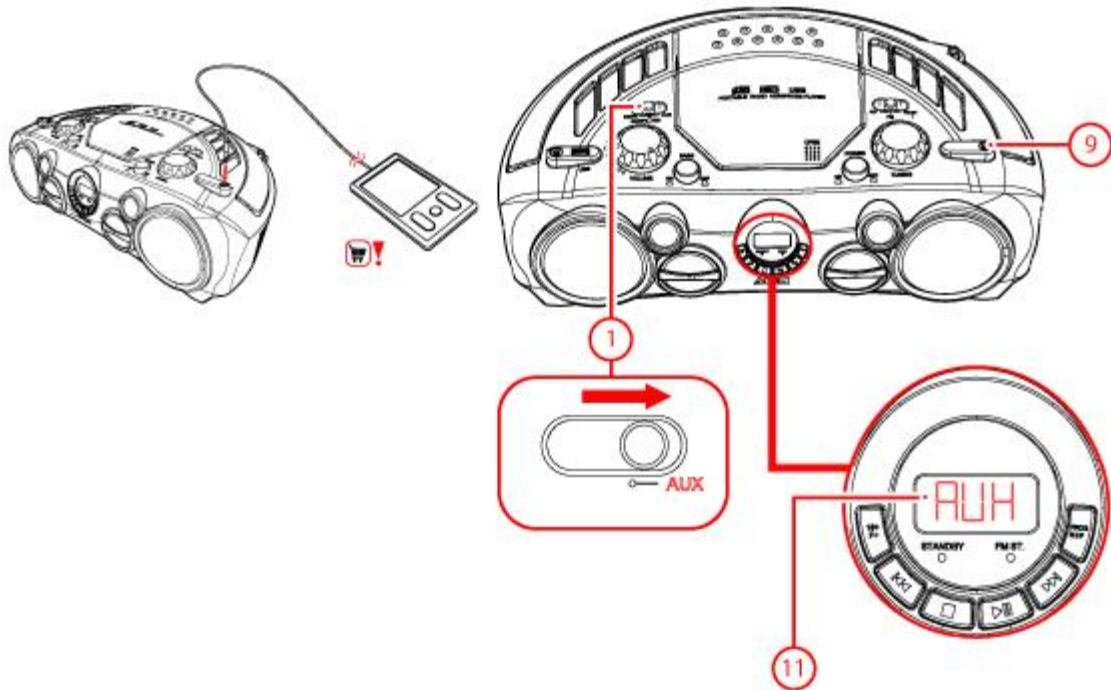

- To select the AUX function, slide the FUNCTION switch (1) to AUX.
  - Connect the external appliance to your APRC90AT (9).
- AUX (11) appears on the display.

## 5.6. Auto Power System (APS)

The Auto Power System (APS) is intended to save energy. In the following situations, the device will go into Standby mode after 15 minutes:

- The FUNCTION (1) switch is in the CD/MP3 position and there is no CD in the CD compartment, or the CD has finished playing.
- The FUNCTION (1) switch is in the USB position and there is no USB drive in the USB port, or the USB drive has finished playing.
- The FUNCTION (1) switch is in the AUX position and there is no AUX cable connected.

## 6.Cleaning and maintenance



**WARNING** Before performing any cleaning or maintenance, switch off and unplug the appliance. Clean the outside of the appliance with a soft cloth. When the appliance is very dirty, dampen the cloth slightly with water and a neutral solution.

### 6.1. Handle and care of a disc

- Hold the disc with fingers. Hold the disc outer edge and/or the centre spindle hole. Do not touch the disc surface.
- Do not bend or press the disc. Do not expose the disc to direct sunlight or heating sources.
- Clean the disc surface with a soft, dry cleaning cloth. Wipe the disc surface gently, radially, from centre towards the outer edge.
- Do not apply thinner, alcohol, chemical solvent, or sprays when cleaning. Such cleaning fluids will permanently damage the disc surface.

## 7. Technical data

### Specifications

Voltage: 230VAC / 50 Hz

Speaker output: 4 x 6 Ohms 8 Watt (2 x 3 inch, 2 x 2 inch) 2 x 6 Ohms 5 W (2 x 1.5 inch)

Max power: 2 x 5 Watt RMS

Battery size: UM-1 / D (8x)

Disc types: CD/ CD-R/ CD-RW

Maximum USB memory: 16 GB

Audio formats: MP3

### Frequency range

FM radio: 87,5 - 108 Mhz

AM radio: 520 - 1620 kHz

Dimensions: 16 x 38,5 x 24,4 cm

### Accessories

- Mains cable
- User manual



## 8. Disposal of used electrical and electronic equipment



The meaning of the symbol on the material, its accessory or packaging indicates that this product shall not be treated as household waste. Please, dispose of this equipment at your applicable collection point for the recycling of electrical and electronic equipments waste. In the European Union and Other European countries which there are separate collection systems for used electrical and electronic product. By ensuring the correct disposal of this product, you will help prevent potentially hazardous to the environment and to human health, which could otherwise be caused by unsuitable waste handling of this product. The recycling of materials will help conserve natural resources. Please do not therefore dispose of your old electrical and electronic equipment with your household waste.

For more detailed information about recycling of this product, please contact your local city office, your household waste disposal service or the shop where you purchased the product.

For more information and warranty conditions, please visit: [www.akai.eu](http://www.akai.eu)



Do not dispose of batteries as household waste but take them to a battery recycling facility.