

INSTRUCTION MANUAL

DESCRIPTION

1. AUTO-OFF-ON
2. VOLUME CONTROL
3. TIME SET
4. ALARM SET
5. ALARM OFF
6. SLEEP SET
7. HOUR SET
8. MINUTE SET
9. CLOCK DISPLAY
10. SNOOZE
11. BAND SWITCH
12. TUNING
13. BATTERY COMPARTMENT
14. SPEAKER

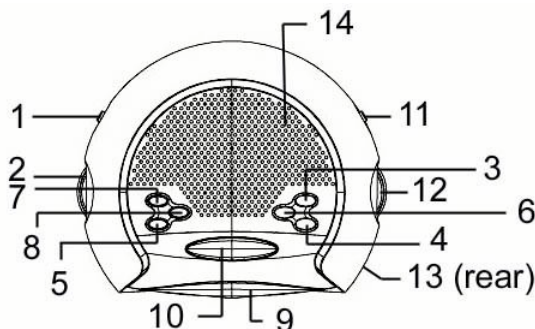

CONNECTING THE RADIO

PLUG THE AC CORD INTO THE POWER OUTLET. WHEN ELECTRICAL POWER HAS BEEN INTERRUPTED AND RESTORED, THE CLOCK DISPLAY WILL BLINK. MAKE SURE TO RESET BOTH THE CORRECT TIME AND ALARM TIME FOR PROPER OPERATION.

TIME SETTING

PRESS AND HOLD THE TIME SET (3). PRESS THE MINUTE SET (8) OR HOUR SET (7) TO SET THE CLOCK DISPLAY TO THE CORRECT TIME. RELEASE THE MINUTE SET (8) AND HOUR SET (7) WHEN FINISHED THE SETTING.

RADIO OPERATION

SLIDE THE AUTO-OFF-ON (1) TO "ON". SELECT THE DESIRED BAND WITH THE BAND SWITCH (11). ADJUST TUNING (12) AND VOLUME (2) FOR THE DESIRED STATION AND LISTENING LEVEL.

SLEEP TO MUSIC

SLIDE THE AUTO-OFF-ON (1) TO EITHER "OFF" OR "AUTO". PRESS THE SLEEP SET (6) ONCE. YOU CAN HAVE 59 MINUTES PLAYING THE RADIO TO ACCOMPANY YOU TO SLEEP. TO SET FOR A DESIRED PERIOD OF SLEEP, SIMPLY PRESS AND HOLD SLEEP SET (6) AND THEN PRESS MINUTE SET (8) TO SET THE DESIRED PERIOD OF THE SLEEP FUNCTION. PRESS THE SLEEP SET (6) AND THE HOUR SET (7) SIMULTANEOUSLY FOR ONE HOUR AND 59 MINUTES SLEEP TIME. IF YOU WANT TO TURN OFF THE RADIO BEFORE SLEEP TIME HAS EXPIRED, PRESS SNOOZE BUTTON (10) ONCE.

WAKE TO MUSIC

PRESS AND HOLD THE ALARM SET (4). PRESS THE HOUR SET (7) OR MINUTE SET (8) TO SET THE DESIRED WAKE UP TIME. RELEASE THE ALARM SET BUTTON (4) TO SHOW THE CURRENT TIME. SLIDE THE AUTO-OFF-ON (1) TO "AUTO". THE RADIO WILL PLAY AUTOMATICALLY AT THE PRESENT TIME.

WAKE TO BUZZER ALARM

FOLLOW THE STEPS OF "WAKE TO MUSIC". YOU WILL BE AWAKENED BY THE BUZZER ALARM. IF YOU WANT TO STOP THE ALARM, SWITCH AUTO-OFF-ON (1) TO "OFF" OR PRESS THE ALARM SET (4) ONCE.

SNOOZE OPERATION

WHEN THE ALARM IS ON, PRESS SNOOZE (10) ONCE. AFTER 9 MINUTES, THE ALARM WILL BE ON AGAIN.

TO GO TO SLEEP AND WAKE TO MUSIC

REPEAT THE STEPS OF "WAKE TO MUSIC". PRESS SLEEP SET (6) TO SET FOR A DESIRED PERIOD OF RADIO PLAYING BEFORE SLEEP. THE RADIO WILL STOP AUTOMATICALLY AND WILL START AGAIN AT THE PRESET WAKE UP TIME.

BATTERY BACKUP

THIS CLOCK HAS A BACKUP POWER SYSTEM TO ENSURE CONTINUOUS OPERATION DURING POWER FAILURE. INSERT ONE 9-VOLT BATTERY AND THE CLOCK MECHANISM WILL CONTINUE TO MAINTAIN THE CURRENT TIME AND ALARM PROGRAM.

DRIPPING & VENTILATION WARNING

THE PRODUCT SHALL NOT BE EXPOSED TO DRIPPING OR SPLASHING AND THAT NO OBJECTS FILLED WITH LIQUIDS, SUCH AS VASES, SHALL BE PLACED ON THE PRODUCT. THE NORMAL VENTILATION OF THE PRODUCT SHALL NOT BE IMPEDED FOR INTENDED USE.



