

AKAI

APRC55BK – Portable radio/CD player

USER MANUAL

EN



Table of contents

1	Safety	3
1.1	Intended use	3
1.2	Labels in this manual	3
1.3	General safety instructions	3
<hr/>		
2	Preparations for use	5
2.1	Unpacking	5
2.2	Package contents	5
<hr/>		
3	Installation	6
3.1	Connecting to the mains	6
3.2	Install batteries	7
<hr/>		
4	Functions	8
4.1	APRC55BK	8
<hr/>		
5	Operation	10
5.1	Setting the clock	10
5.2	Setting an alarm	11
5.3	Using the timer	12
5.4	Radio functions	13
5.5	CD functions	14
5.6	USB and memory card	16
5.7	AUX IN	17
5.8	Operation with BLUETOOTH	18
5.9	Auto Power System (APS)	19
<hr/>		
6	Cleaning and maintenance	20
6.1	Handle and care of a disc	20
<hr/>		
7	Technical data	21
<hr/>		
8	Disposal of used electric and electronic equipment	22
<hr/>		

1 Safety

1.1 Intended use

The device functions as a portable radio/CD audio player. The device can play music (MP3) via CD, USB and SD card. Music can be played wirelessly via the bluetooth connection. It is also possible to play music via the AUX port.

 Read the manual carefully before the first use.

1.2 Labels in this manual

 **WARNING** A warning means that injury or death is possible if the instructions are not obeyed.

 **CAUTION** A caution means that damage to the equipment is possible.

 A note gives additional information, e.g. for a procedure.

1.3 General safety instructions

 **WARNING** Do not put force on the appliance. The appliance can fall and can cause serious injury.

 **WARNING** Do not insert any objects in the ventilation holes.

 This appliance employs a laser system. To prevent direct exposure to the laser beam, do not open the appliance. Visible laser radiation when open and interlock defeated.

 To prevent hearing damage, remember to adjust the volume to a comfortable level.

 **CAUTION** Do not spill any liquid on the appliance.

 **CAUTION** Do not block the ventilation holes.

 This appliance is double insulated; therefore no earth wire is required. Always check that the mains voltage corresponds to the voltage on the rating plate.

 This appliance is double insulated; therefore no earth wire is required. Always check that the mains voltage corresponds to the voltage on the rating plate.

2 Preparations for use

2.1 Unpacking

- Check the package contents as described below. If any item is missing, please contact your reseller.
- Remove the labels from the front panel carefully if present.

i We recommend that you retain the original carton and packing materials in case it ever becomes necessary to return your product for service. This is the only way to safely protect the product against damage in transit. If you do dispose of the carton and the packing materials, please remember to recycle with due care to the environment.

2.2 Package contents

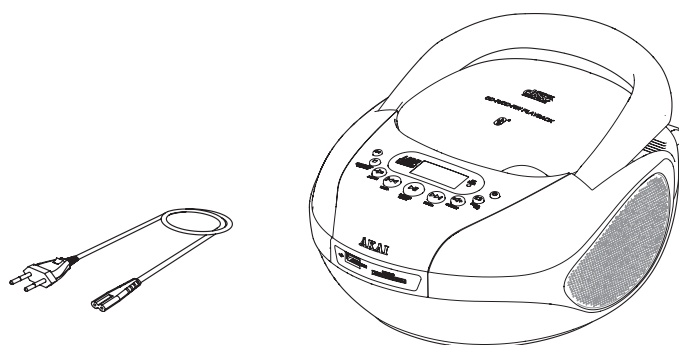

The following items are included in the received package:

- 1 x APCR55BK
- 1 x Quick start guide
- 1 x Mains cable

i If any item is missing, please contact your reseller.

3 Installation

- Put the appliance on a horizontal flat surface.
- Connect the appliance to the mains.

⚠ CAUTION Do not put the appliance near a heat source.

⚠ CAUTION Do not expose the appliance to direct sunlight.

- i** This appliance is equipped with rubber feet to prevent it from moving. The feet are made from non-migrating material specially formulated to avoid leaving any marks or stains on furniture. However, certain types of furniture polishes, wood preservatives or cleaning sprays cause the rubber to soften and leave marks or a residue on the furniture, and potentially risk the surface to become damaged. To prevent damage to wooden surfaces, we recommend that you apply self-adhesive pads to the bottom of the rubber feet before installation.

3.1 Connecting to the mains

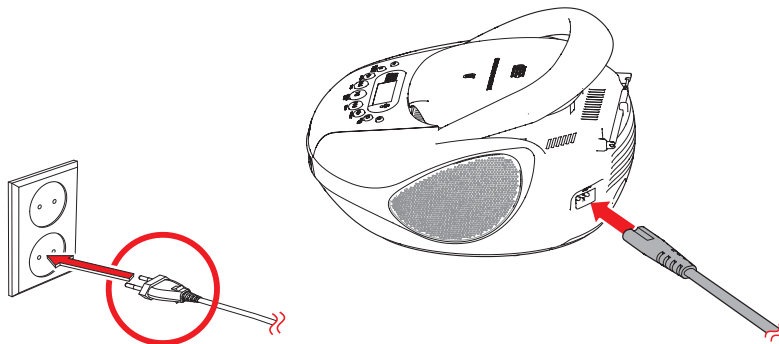

- Connect the 8-shaped connector of the power cable to the device's power connection.
- Connect the mains plug to a wall socket.

3.2 Install batteries

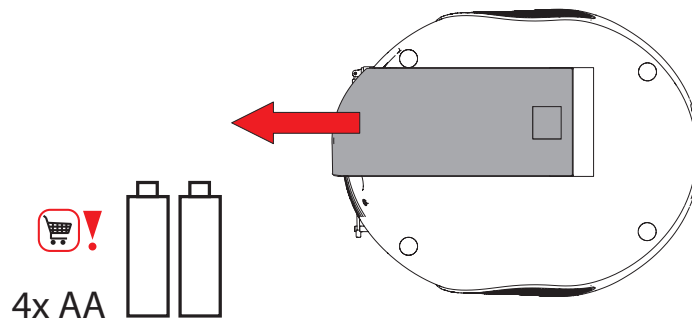

The appliance can also be operated on battery power. For this purpose, the appliance uses six batteries (AA).

i Please note: these batteries are not included.

i If you do not use the appliance for an extended period, remove the batteries.

Install batteries

- Remove the battery cover.
- Insert the batteries matching the (+) and (-) polarity markings.
- Re-install the battery cover.

⚠ CAUTION Incorrect installation can cause battery leakage and corrosion which will damage the appliance. Corrosion, oxidation, battery leakage and any other gradually acidic defect of this nature will invalidate the guarantee.

4 Functions

4.1 APRC55BK

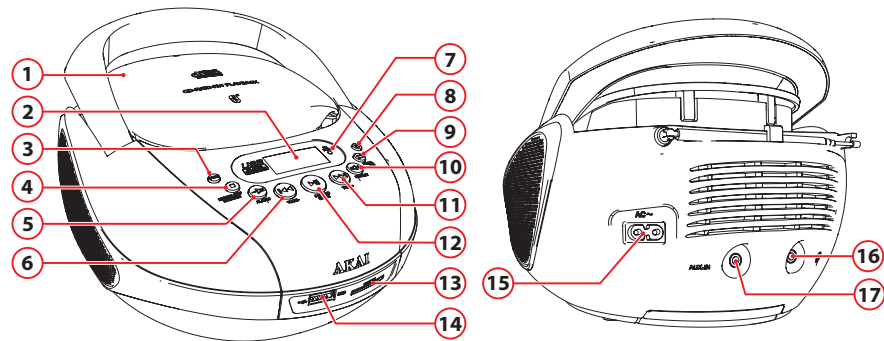

- | | |
|----------------------------------------|-------------------------------------|
| 1. CD compartment | 9. PROGRAM/REPEAT/+10 button |
| 2. LCD Display | 10. VOL+/CLOCK button |
| 3. FUNCTION button | 11. NEXT/TUNE+ button |
| 4. STOP/MEMORY/SLEEP/
SNOOZE button | 12. PLAY/PAUSE/PAIRING/MO-ST button |
| 5. VOL-/ALARM button | 13. Memory card slot (SD/MMC) |
| 6. PREV/TUNE- button | 14. USB slot |
| 7. REPEAT iBLUETOOTH | 15. Plug contact |
| 8. STANDBY button | 16. Headphone jack |
| | 17. AUX jack: 3.5 mm |

General functions

FUNCTION button

- To select the source mode , press the FUNCTION button (3).

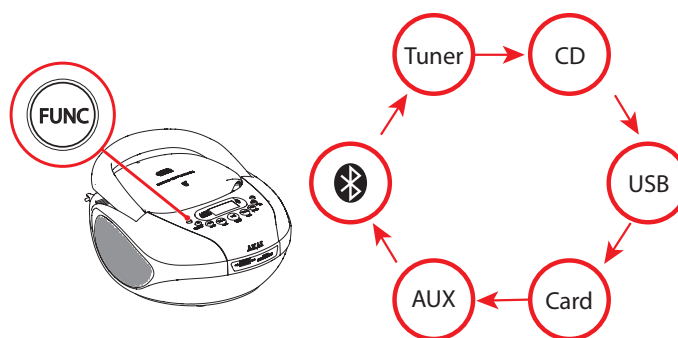

Digital volume control

- To adjust the volume, press the VOL - (5) button or the VOL + button (5).

Using the REPEAT/RANDOM function

- Press the PROG./+10 button (9) once to repeat the current chapter or track.
- Press the button twice to repeat all chapters or tracks.
- Press the button 3 times to play all tracks in random order. The repeat function is now off.
- Press the button once again to cancel the function.

Headphone jack (16)

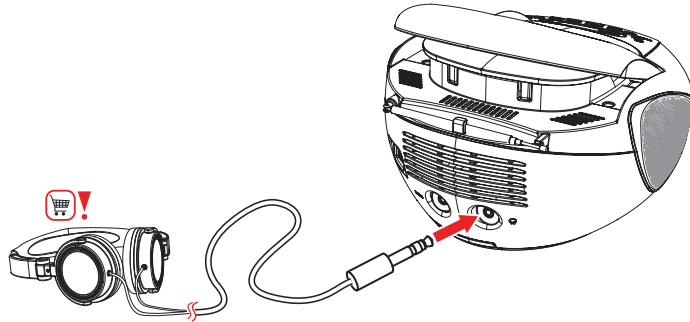

- To connect a headphone, insert the cable plug in the headphone jack. To prevent hearing damage, remember to adjust the volume to a comfortable level.

5 Operation

5.1 Setting the clock

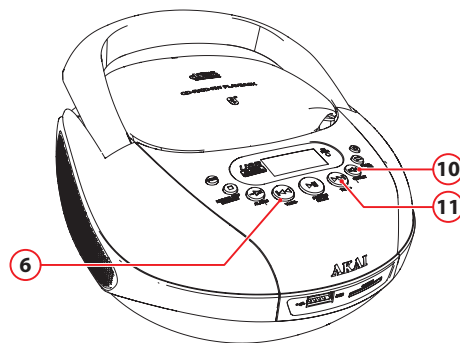

- Set the appliance in the standby mode.
- Keep key CLK.SET (10) pressed for 2 seconds
- Press the PREV (6) or NEXT (11) key to choose between 24 or 12 hour time display.
- "12H" or "24H" appears on the display.
- Press CLK.SET (10) to confirm.
- Press the PREV (6) or NEXT (11) key to set the desired hour.
- Press CLK.SET (10) to confirm.
- Press the PREV (6) or NEXT (11) key to set the desired minutes.
- Press CLK.SET (10) to confirm.

i The time will flash in the display if it has not been set properly.

5.2 Setting an alarm

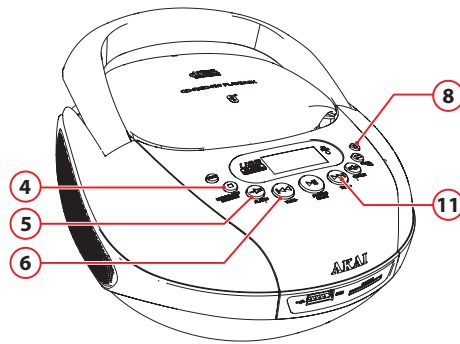

i Caution! You can set and activate two alarms.

Alarm 1

- Set the appliance in the standby mode.
- Keep key ALARM (5) pressed for 2 seconds
"AL1" appears on the display.
- Press the PREV (6) or NEXT (11) key to set the desired hour.
- Press ALARM (5) to confirm.
- Press the PREV (6) or NEXT (11) key to set the desired minutes.
- Press ALARM (5) to confirm.
- To select the source mode (TUNER/CD/CARD/USB/BUZZ), press the PREV (6) button NEXT (11).
- Press ALARM (5) to confirm.

i When the source mode CD has been selected, a CD must be in the appliance. If there is no CD, the alarm will not go off.

i When the source mode USB or CARD has been selected and there is no USB or memory card present, the radio mode will be switched on when the alarm goes off.

Alarm 2

- To do this, repeat the last 10 steps.

Activating the alarm 1

- Press the ALARM key once (5).

Activating the alarm 2

- Press the key ALARM (5) twice,
- Press the button 3 times to switch on two alarms.
- Press the button once again to cancel the function.

Snooze alarm

- To snooze the alarm, press SNOOZE (4). The alarm sounds again after the snooze time has elapsed.
The default snooze time is: 6 minutes.

Turn off alarm

- Press the STANDBY key once (8).

5.3 Using the timer

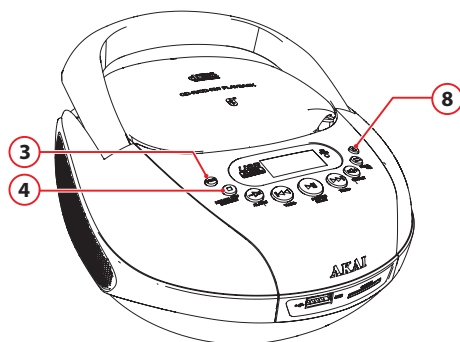

- Select the desired source .
To do this, press the FUNCTION key (3).
- Keep key SLEEP (4) pressed for 2 seconds
"SLEEP" appears on the display.
- Press the button SLEEP (4) repeatedly until the desired setting is found.
The appliance stops playing after the chosen time has elapsed.
- To cancel the SLEEP function, press the STANDBY button (8).

5.4 Radio functions

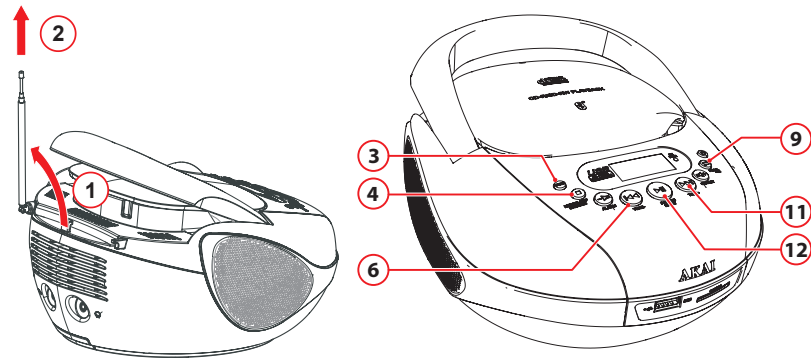

- Slide out the antenna
- To select the source mode TUNER, press the FUNCTION button (3).
"FM" appears on the display.

To switch between Mono and Stereo reception, press the MO/ST button (12).

Automatically adjust the frequency

- Keep key PLAY/PAUSE (12) pressed for 2 seconds
- To skip to the next preset station, press the PREV button (6) or the NEXT button (11).

Adjust the frequency manually

- To tune to the station of your choice, press the PREV (6) button or the NEXT (11) button repeatedly until the frequency is found.

Save a radiostation into the memory

- Press the PROGRAM button (9).
"P01" appears on the display.
- Press the PREV (6) or NEXT (11) key to select a memory location.
- Press PROGRAM (9) to confirm.
20 memory locations are available.

Activating a stored function

- Press the MEMORY button (4).

5.5 CD functions

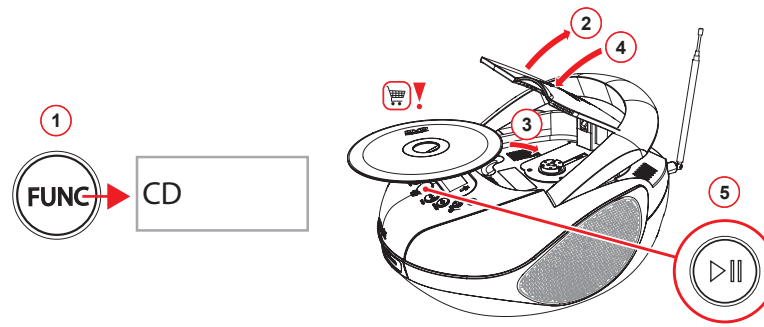

To insert a CD:

- Press the CD compartment (1) to open the appliance
- Insert the CD with the label upwards
- Close the CD compartment

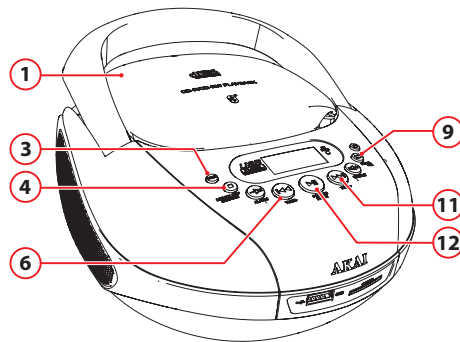

Playing a CD:

⚠ Make sure that no external device is connected to the AUX IN port.

- To select the source mode CD, press the FUNCTION button (3). "CD" appears on the display.
- To start playback, press the PLAY/PAUSE button (12) once.

During playback, the following functions are available:

- To select a track, press the PREV button (6) or the NEXT button (11) until the desired track is set.
- Press and hold the PREV button (6) or the NEXT button (11) to rewind or forward the track.
- To pause playback, press the PLAY/PAUSE button (12) once; to resume playback, press the button again.
- To stop playback, press the STOP button (4).
- Hold down the button PROG./+10 (9) to go to the following 10 numbers.
- Press the button PROG./+10 (9) to select the next folder on an MP3 disc or a USB flash drive

Program track sequence

- To stop playback, press the STOP button (4).
- To play a list of tracks (max. 20) in a program, press the PROG./+10 button (9).
"P01" appears on the display.
MEMORY appears on the display.
- Press the PREV button (6) or the NEXT button (11) to select a desired track.
- Press the PROG./+10 button (9) to confirm the selection. Repeat the previous step to select more tracks and confirm every selection with the PROG./+10 button (9).
- Press the PLAY/PAUSE button (12) to start the program.

To play the program again, press the PROG./+10 button (9) after the program has finished. Press the PLAY/PAUSE button (12) to start the program again.

- To stop the program during playback, press the STOP button (4).
- To delete the program during the playback, press the STOP button (4) twice.

5.6 USB and memory card

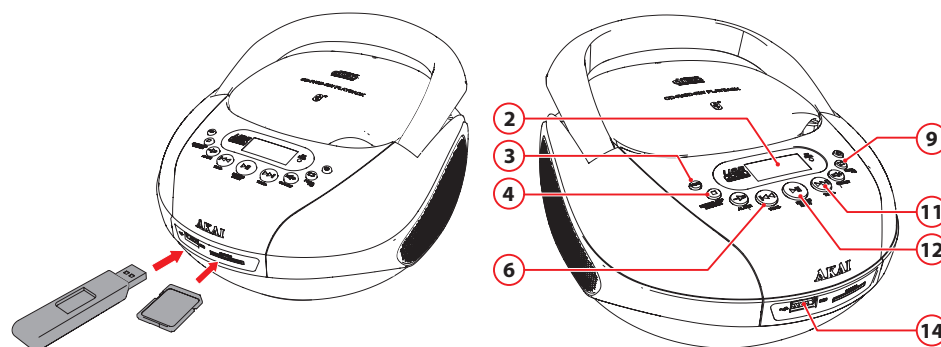

i Due to the great variety of products with USB ports and their sometimes quite manufacturer-specific functions we can neither guarantee that all devices will be recognised, nor that all operating options that are possible in theory will actually work.

USB functions

- Insert the USB device in the slot (14). The device can only be connected one way.
- To select the source mode USB, press the FUNCTION button (3). USB appears on the display.

After connecting the appliance, the contents are loaded.

Next, the total number of tracks appears on the display (2).

- To start playback, press the PLAY/PAUSE button (12) once.

Memory card functions

- Insert the SD/MMC device in the slot. The device can only be connected one way.
- To select the source mode CARD, press the FUNCTION button (3). CARD appears on the display.

After connecting the appliance, the contents are loaded.

Next, the total number of tracks appears on the display (2).

- To start playback, press the PLAY/PAUSE button (12) once.

During playback, the following functions are available:

- To select a track, press the PREV button (6) or the NEXT button (11) until the desired track is set.
- Press and hold the PREV button (6) or the NEXT button (11) to rewind or forward the track.
- To pause playback, press the PLAY/PAUSE button (12) once; to resume playback, press the button again.

- Press the button PROG./+10 (9) to select the next folder on an MP3 disc or a USB flash drive
 - To stop playback, press the STOP button (4).
- To remove the device, gently pull it out of the slot.

5.7 AUX IN

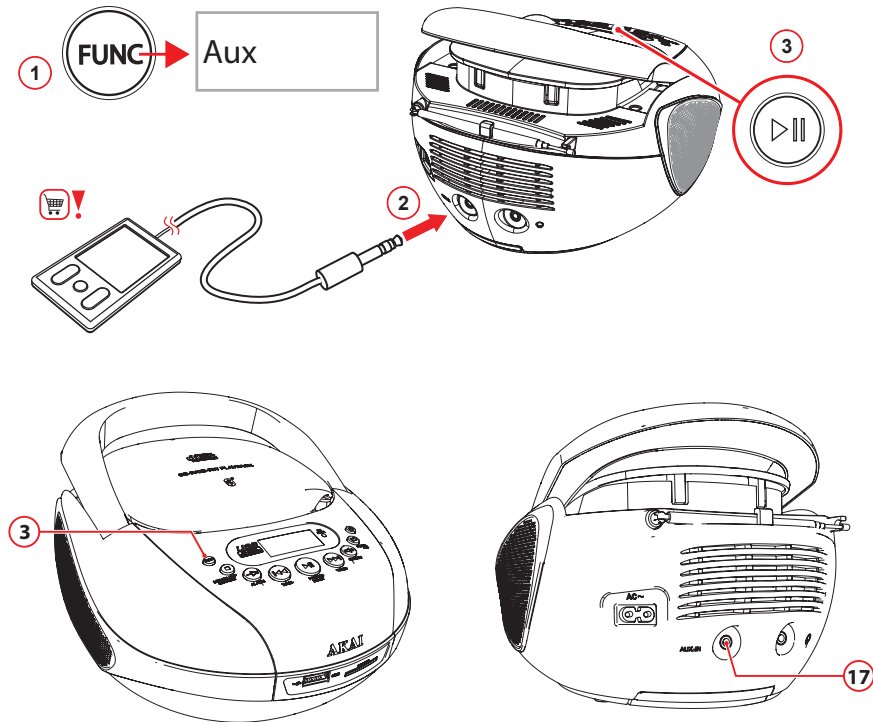

- To connect an external audio device, insert the cable plug in the AUX IN jack (17).
- To select the source mode AUX, press the FUNCTION button (3). "AUX" appears on the display.

5.8 Operation with BLUETOOTH

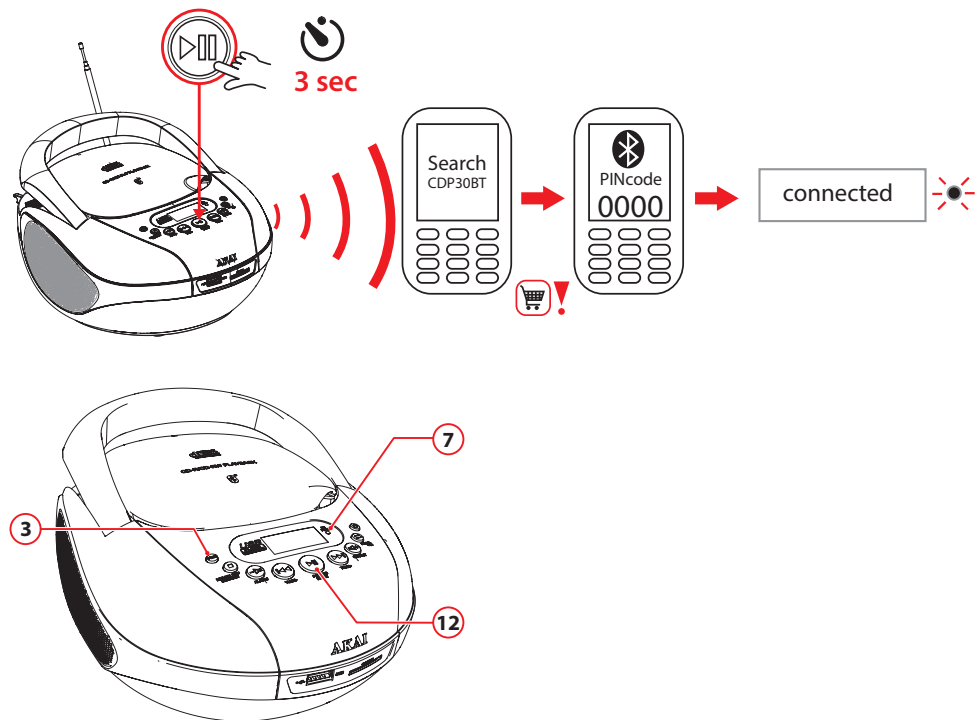

You can wirelessly connect the APRC55BK to devices that have Bluetooth A2DP.

Preparation

- To select the source mode BLUETOOTH, press the FUNCTION button (3).
"BT" appears on the display.
- You will see the blue LED flashing (7).
Your APRC55BK is now ready to establish a wireless connection with your Bluetooth device.

Establishing a Bluetooth connection (PAIREN)

- Turn on the Bluetooth function of your device
- Go to the Bluetooth Menu of your Bluetooth device.
- Search Bluetooth devices and select CDP30BT to establish connection
- Enter "0000" when the player asks for the PIN code
The blue LED remains lit as soon as the connection has been established.

Making a manual Bluetooth connection.

- Turn on the Bluetooth function of your device
- Go to the Bluetooth Menu of your Bluetooth device.
- Keep key PAIRING (12) pressed for 3 seconds
- Search Bluetooth devices and select CDP30BT to establish connection

- Enter "0000" when the player asks for the PIN code
The blue LED remains lit as soon as the connection has been established.

i NOTE: your Bluetooth connection has a range of approximately 10 metres

Reconnect via Bluetooth

If you move outside the Bluetooth range, the connection will be automatically terminated.

The Bluetooth connection will be recovered again as soon as you come within the Bluetooth range.

5.9 Auto Power System (APS)

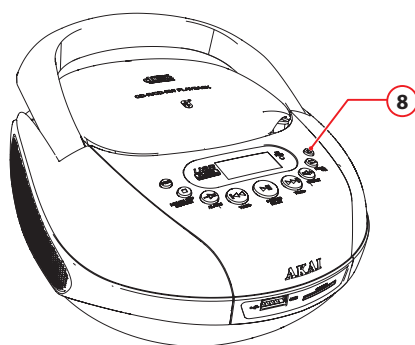

The Auto Power System (APS) is intended to save energy. In the following situations, the device will go into Standby mode after 15 minutes:

- After playing, the following source mode ends:
 - CD
 - USB
 - CARD
- To switch on the appliance, press the STANDBY button (8).

6 Cleaning and maintenance

⚠ WARNING Before performing any cleaning or maintenance, switch off and unplug the appliance.

- Clean the outside of the appliance with a soft cloth. When the appliance is very dirty, dampen the cloth slightly with water and a neutral solution.

6.1 Handle and care of a disc

- Hold the disc with fingers. Hold the disc outer edge and/or the centre spindle hole. Do not touch the disc surface.
- Do not bend or press the disc. Do not expose the disc to direct sunlight or heating sources.
- Clean the disc surface with a soft, dry cleaning cloth. Wipe the disc surface gently, radially, from centre towards the outer edge.
- Do not apply thinner, alcohol, chemical solvent, or sprays when cleaning. Such cleaning fluids will permanently damage the disc surface.

7 Technical data

Specifications

- Voltage: 110-230VAC ~ 50/60 Hz
- Power consumption: 14 Watt
- Standby power consumption: < 1 Watt
- Speaker output: 2 x 1,5 W RMS
- Max power: 2 x 1,8 Watt RMS
- Battery size: AA (4x)
- Disc types: CD/ CD-R/ CD-RW
20 memory locations are available.
- Maximum USB memory: 16 GB
- Audio formats: MP3
- Frequency range: 87,5 - 108 Mhz
20 memory locations are available.
- Dimensions: 25 x 11 x 20,3 cm
- Weight: 1100 g.
- LCD Display
- USB slot
- Memory card slot (SD/MMC)
- Headphone jack
- AUX jack: 3.5 mm
- Bluetooth connection

Accessories

- 1 x Mains cable
- User manual

8 Disposal of used electric and electronic equipment



The meaning of the symbol on the material, its accessory or packaging indicates that this product shall not be treated as household waste. Please, dispose of this equipment at your applicable collection point for the recycling of electrical and electronic equipments waste. In the European Union and Other European countries which there are separate collection systems for used electrical and electronic product. By ensuring the correct disposal of this product, you will help prevent potentially hazardous to the environment and to human health, which could otherwise be caused by unsuitable waste handling of this product. The recycling of materials will help conserve natural resources. Please do not therefore dispose of your old electrical and electronic equipment with your household waste.

Do not dispose of batteries as household waste but take them to a battery recycling facility.

For more detailed information about recycling of this product, please contact your local city office, your household waste disposal service or the shop where you purchased the product.

For more information and warranty conditions, please visit: www.akai.eu