

AKAI

Portable radio/(MP3)CD player with USB port

APRC21U



User manual

Gebruiksaanwijzing

Manuel de l'utilisateur

Brugsanvisning

GB 2

NL 15

FR 29

DA 43

Table of contents

1.	Safety	3
	1.1 Intended use	3
	1.2 Labels in this manual	3
	1.3 General safety instructions	3
2.	Preparations for use	4
	2.1 Unpacking	4
	2.2 Package contents	4
3.	Installation	5
	3.1 Connecting to the mains	5
	3.2 Battery power	6
4.	Functions	7
5.	Operation	8
	5.1 Master power switch	8
	5.2 General functions	8
	5.3 Radio functions	8
	5.4 CD functions	9
	5.5 USB functions	10
6.	Cleaning and maintenance	12
	6.1 Handle and care of a disc	12
7.	Troubleshooting	12
8.	Technical data	13
9.	Disposal of used electrical and electronic equipment	14

Copyright notice

Design and specifications are subject to change without notice.

1. Safety

1.1 Intended use

The radio/CD player plays music from USB, CD and radio. Read the manual carefully before first use.

1.2 Labels in this manual



WARNING

A warning means that injury or death is possible if the instructions are not obeyed.



CAUTION

A caution means that damage to the equipment is possible.



A note gives additional information, e.g. for a procedure.

1.3 General safety instructions



WARNING

Do not put force on the appliance. The appliance can fall and can cause serious injury.



CAUTION

Do not spill any liquid on the appliance.



WARNING

Do not insert any objects in the ventilation holes.



CAUTION

Do not block the ventilation holes.



This appliance is double insulated; therefore no earth wire is required. Always check that the mains voltage corresponds to the voltage on the rating plate.

CLASS 1
LASER PRODUCT

This appliance employs a laser system. To prevent direct exposure to the laser beam, do not open the appliance. Visible laser radiation when open and interlock defeated.

Notice:

Please plug the usb device to the USB port directly. not suggest to connect with USB extension cable.

2. Preparations for use

2.1 Unpacking

- Unpack the appliance carefully.
- Check the package contents as described below. If any item is missing, please contact your reseller.
- Remove the labels from the front panel carefully if present.



We recommend that you retain the original carton and packing materials in case it ever becomes necessary to return your product for service. This is the only way to safely protect the product against damage in transit. If you do dispose of the carton and the packing materials, please remember to recycle with due care to the environment.

2.2 Package contents

The following items are included in the received package:

- 1 Radio/CD player
- 1 Mains cable
- 1 Operator manual



If any item is missing, please contact your reseller.

3. Installation

- Put the appliance on a horizontal flat surface.
- Connect the appliance to the mains.
Read the paragraph "Connecting to the mains".



CAUTION

- Do not put the appliance near a heat source.
- Do not expose the appliance to direct sunlight.



This appliance is equipped with rubber feet to prevent it from moving. The feet are made from non-migrating material specially formulated to avoid leaving any marks or stains on furniture. However, certain types of furniture polishes, wood preservatives or cleaning sprays cause the rubber to soften and leave marks or a residue on the furniture, and potentially risk the surface to become damaged. To prevent damage to wooden surfaces, we recommend that you apply self-adhesive pads to the bottom of the rubber feet before installation.

3.1 Connecting to the mains

- Connect the female connector on the mains cable to the AC MAINS connection.
- Connect the mains plug to a wall socket.

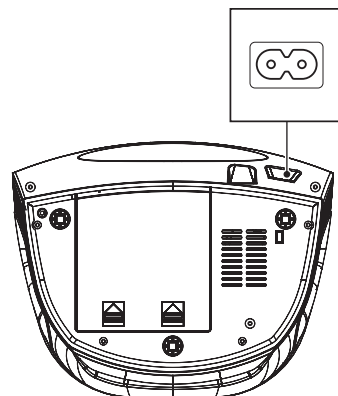

3.2 Battery power

The appliance can also be operated on battery power. For this purpose, the appliance uses eight batteries (size C).



- Batteries are not included with this appliance.
- Batteries are not necessary for normal operation.

Installing the batteries

- Remove the battery cover.
- Insert the batteries matching the (+) and (-) polarity markings.
- Re-install the battery cover.

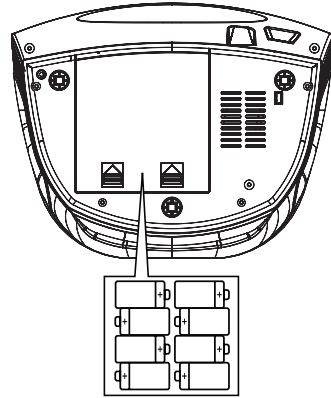

CAUTION

Incorrect installation can cause battery leakage and corrosion which will damage the appliance. Corrosion, oxidation, battery leakage and any other gradually acidic defect of this nature will invalidate the guarantee.

4. Functions

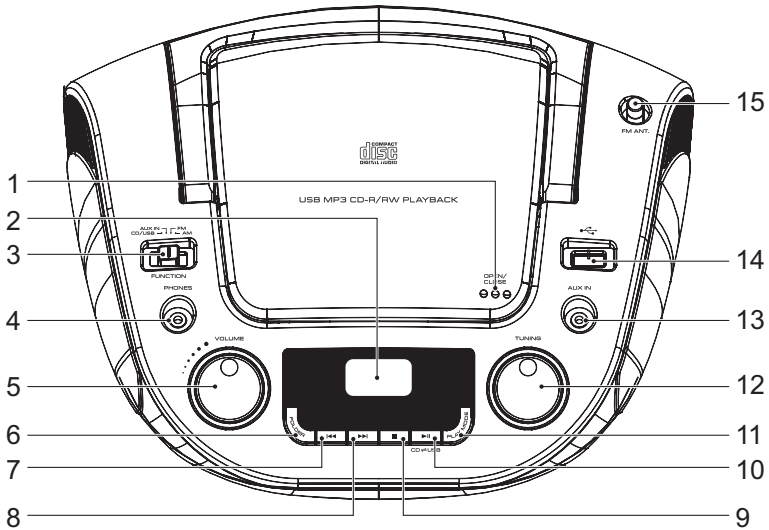

- | | | | |
|---|-----------------|----|--------------------------------------|
| 1 | CD compartment | 9 | STOP button |
| 2 | Display | 10 | PLAY/PAUSE button /
CD~USB button |
| 3 | FUNCTION switch | 11 | PLAY MODE button |
| 4 | Headphone jack | 12 | TUNING dial |
| 5 | VOLUME dial | 13 | AUX IN jack |
| 6 | FOLDER button | 14 | USB slot |
| 7 | PREV button | 15 | FM antenna |
| 8 | NEXT button | | |

Back panel

- 16 Master power switch

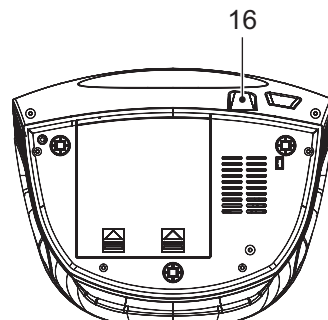

5. Operation

5.1 Master power switch

The appliance is equipped with a master power switch (16) located at the back panel.

- Set the switch into the ON position prior to taking the appliance into operation.
- Set the switch into the OFF position prior to disconnecting from the mains.



When the appliance is not in use for longer period, we recommend to switch the appliance off at the master power switch.

5.2 General functions

- To select the source mode (CD/USB, AUX IN, FM, AM), move the FUNCTION switch (3) to the desired position.
- To adjust the volume level, turn the VOLUME dial (5) until the desired level is set.
- To connect an external audio device, insert the cable plug in the AUX IN jack (13).
- To connect a headphone, insert the cable plug in the headphone jack (4). To prevent hearing damage, remember to adjust the volume to a comfortable level.

5.3 Radio functions

- Switch on the appliance. Select the tuner mode.
- To select the radio band, move the FUNCTION switch (3) to the AM or FM position.
- To select a frequency or radio station, turn the TUNING dial (12) until the desired frequency is set. The display (2) shows the selected frequency.



To improve the reception of the FM frequency, extend the aerial antenna. To improve the reception of the AM frequency, turn the appliance.

5.4 CD functions

- Switch on the appliance.
- Move the FUNCTION switch (3) to the position CD/USB.
- If the appliance is in USB mode, press the CD~USB button (10) to select the CD mode.
- To insert a CD:
 - Press the CD compartment (1) to open the appliance.
 - Insert the CD with the label upwards.
 - Close the CD compartment (1).

The display shows the total number of tracks on the CD.

- To start playback, press the PLAY/PAUSE button (10).

During playback, the following functions are available:

- To select a track, press the PREV button (7) or the NEXT button (8) until the desired track is set.
- To search for a specific point on the disc, hold the PREV button (7) or the NEXT button (8) until the point is reached and release the button.
- To pause playback, press the PLAY/PAUSE button (10).
To resume playback, press the PLAY/PAUSE button (10) again.
- To stop playback, press the STOP button (9).

Using the REPEAT/RANDOM function

This function is available in PLAY mode only.

The possible entries for CD are:

- Press the PLAY MODE button (11) to repeat the current title.
- Press the PLAY MODE button (11) again (2x) to repeat all tracks.
- Press the PLAY MODE button (11) again (3x) to play all tracks in random order. The repeat function is now off.

The possible entries for MP3 CD are:

- Press the PLAY MODE button (11) to repeat the current title.
- Press the PLAY MODE button (11) again (2x) to repeat all tracks.
- Press the PLAY MODE button (11) again (3x) to repeat all titles in an index.
- Press the PLAY MODE button (11) again (4x) to play all tracks in random order. The repeat function is now off.

Using the PROGRAM function

To use the PROGRAM function for CD/MP3 CD, the playback must be in STOP mode.

- To program a CD:
 - Press the STOP button (9), then press the PLAY MODE button (11).
 - Press the PREV button (7) or the NEXT button (8) to select a desired track. Press the PLAY MODE button (11) to confirm the selection.
 - Repeat the previous step to select more tracks and confirm every selection with the PLAY MODE button (11).
- To program an MP3 CD:
 - Press the STOP button (9), then press the PLAY MODE button (11).
 - Press the FOLDER button (6) to select a folder or a file.
 - Press the PREV button (7) or the NEXT button (8) to select a track. Repeat the previous step to select more tracks and confirm every selection with the PLAY MODE button (11).
- Press the PLAY/PAUSE button (10) to start the program.
- To play the program again, press the PLAY MODE button (11) after the program has finished. Press the PLAY/PAUSE button (10) to start the program again.
- To view the program during playback, press the PREV button (7) or the NEXT button (8).
- To stop the program during playback, press the STOP button (9).
- To delete the program during playback, press the STOP button (9) twice.

5.5 USB functions

- Switch on the appliance.
 - Move the FUNCTION switch (3) to the position CD/USB.
 - If the appliance is in CD mode, press the CD~USB button (10) to select the USB mode.
 - Insert the device in the slot (14). The device can only be connected one way. After the device has been connected, a content menu will display on the TV screen.
 - To start playback, press the PLAY/PAUSE button (10) once.
- During playback, the following functions are available:
- To select a track, press the PREV button (7) or the NEXT button (8) until the desired track is set.
 - To pause playback, press the PLAY/PAUSE button (10). To resume playback, press the PLAY/PAUSE button (10) again.

- To stop playback, press the STOP button (9).
- To remove the device, gently pull it out of the slot.



Due to the great variety of products with USB ports and their sometimes quite manufacturer-specific functions we can neither guarantee that all devices will be recognised, nor that all operating options that are possible in theory will actually work.

Using the PROGRAM function

To use the PROGRAM function for USB, the playback must be in STOP mode.

- To program a USB:
 - Press the STOP button (9), then press the PLAY MODE button (11).
 - Press the FOLDER button (6) to select a folder or a file.
 - Press the PREV button (7) or the NEXT button (8) to select a track. Repeat the previous step to select more tracks and confirm every selection with the PLAY MODE button (11).
- Press the PLAY/PAUSE button (10) to start the program.
- To play the program again, press the PLAY MODE button (11) after the program has finished. Press the PLAY/PAUSE button (10) to start the program again.
- To view the program during playback, press the PREV button (7) or the NEXT button (8).
- To stop the program during playback, press the STOP button (9).
- To delete the program during playback, press the STOP button (9) twice.

Using the REPEAT/RANDOM function

This function is available in PLAY mode only.

The possible entries for USB are:

- Press the PLAY MODE button (11) to repeat the current title.
- Press the PLAY MODE button (11) again (2x) to repeat all tracks.
- Press the PLAY MODE button (11) again (3x) to repeat all titles in an index.
- Press the PLAY MODE button (11) again (4x) to play all tracks in random order. The repeat function is now off.

6. Cleaning and maintenance



WARNING

Before performing any cleaning or maintenance, switch off and unplug the appliance.

- Clean the outside of the appliance with a soft cloth. When the appliance is very dirty, dampen the cloth slightly with water and a neutral solution.
- Clean the lens with a camera lens brush/blower (not included) if the lens is dirty.

6.1 Handle and care of a disc

- Hold the disc with fingers. Hold the disc outer edge and/or the centre spindle hole. Do not touch the disc surface.
- Do not bend or press the disc. Do not expose the disc to direct sunlight or heating sources.
- Clean the disc surface with a soft, dry cleaning cloth. Wipe the disc surface gently, radially, from centre towards the outer edge.
- Do not apply thinner, alcohol, chemical solvent, or sprays when cleaning. Such cleaning fluids will permanently damage the disc surface.

7. Troubleshooting

Trouble	Action
No display	Switch on the appliance. Connect the appliance properly. Select the correct function with the FUNCTION switch (3).
No sound	Connect the appliance properly. Adjust the volume. Adjust tuning control. Check if the CD is inserted with the label upwards. Clean the lens.
No power	Check if the master power switch on the back panel is ON.

MP3 playback

Trouble	Action
No sound or incomplete audio	If MP3 data is mixed with other files on CD, the appliance may play the non-MP3 files as noise or without sound or it rejects the disc. Check if the played file is in MP3 format or select another file to play.

USB playback

Trouble	Action
No playback	USB device is not installed or installed incorrectly. Insert USB device into slot. Incompatible USB device used. Playback using any USB device cannot be guaranteed. Please try another USB device.

8. Technical data

Parameter	Value
Voltage	230 V _{AC} ~ 50 Hz
Power consumption	15 W
Max power output	2 x 1 W (RMS)
Radio bands	AM/FM
Dimensions (W x H x D)	275 x 130 x 218 mm
Weight	1.75 kg

Frequency range

Parameter	Value
AM radio	540 - 1600 kHz
FM radio	87.5 - 108 mHz

Battery power

Parameter	Value
Power consumption	8 x 1.5 V
Battery size	C

9. Disposal of used electrical and electronic equipment



The meaning of the symbol on the material, its accessory or packaging indicates that this product shall not be treated as household waste. Please, dispose of this equipment at your applicable collection point for the recycling of electrical and electronic equipments waste. In the European Union and Other European countries which there are separate collection systems for used electrical and electronic product. By ensuring the correct disposal of this product, you will help prevent potentially hazardous to the environment and to human health, which could otherwise be caused by unsuitable waste handling of this product. The recycling of materials will help conserve natural resources. Please do not therefore dispose of your old electrical and electronic equipment with your household waste.

For more detailed information about recycling of this product, please contact your local city office, your household waste disposal service or the shop where you purchased the product.

For more information and warranty conditions, please visit: **www.akai.eu**